



Cambridge IGCSE™

CANDIDATE
NAME

CENTRE
NUMBER

--	--	--	--	--

CANDIDATE
NUMBER

--	--	--	--

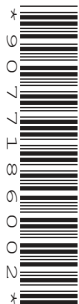

COMBINED SCIENCE

0653/41

Paper 4 Theory (Extended)

May/June 2021

1 hour 15 minutes

You must answer on the question paper.

No additional materials are needed.

INSTRUCTIONS

- Answer **all** questions.
- Use a black or dark blue pen. You may use an HB pencil for any diagrams or graphs.
- Write your name, centre number and candidate number in the boxes at the top of the page.
- Write your answer to each question in the space provided.
- Do **not** use an erasable pen or correction fluid.
- Do **not** write on any bar codes.
- You may use a calculator.
- You should show all your working and use appropriate units.

INFORMATION

- The total mark for this paper is 80.
- The number of marks for each question or part question is shown in brackets [].
- The Periodic Table is printed in the question paper.

This document has **24** pages. Any blank pages are indicated.

1 (a) Fig. 1.1 is a diagram of a human sperm cell.



Fig. 1.1

(i) State the function of the nucleus.

..... [1]

(ii) State one way the sperm is adapted to its function in reproduction.

..... [1]

(iii) Name the part of the male reproductive system that makes sperm.

..... [1]

(b) Fig. 1.2 shows two different types of cells from the leaf of a plant.

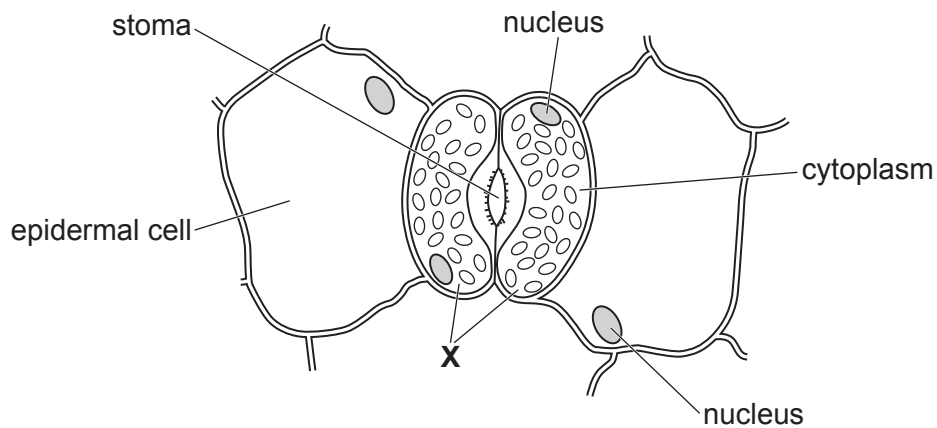

Fig. 1.2

(i) Identify the cells labelled **X** in Fig. 1.2.

..... [1]

(ii) Identify **one** structure in cell **X** in Fig. 1.2 that is absent from a sperm cell.

..... [1]

- (c) A student investigates the effect of light intensity on the rate of photosynthesis in an aquatic plant.

Fig. 1.3 shows the apparatus the student uses.

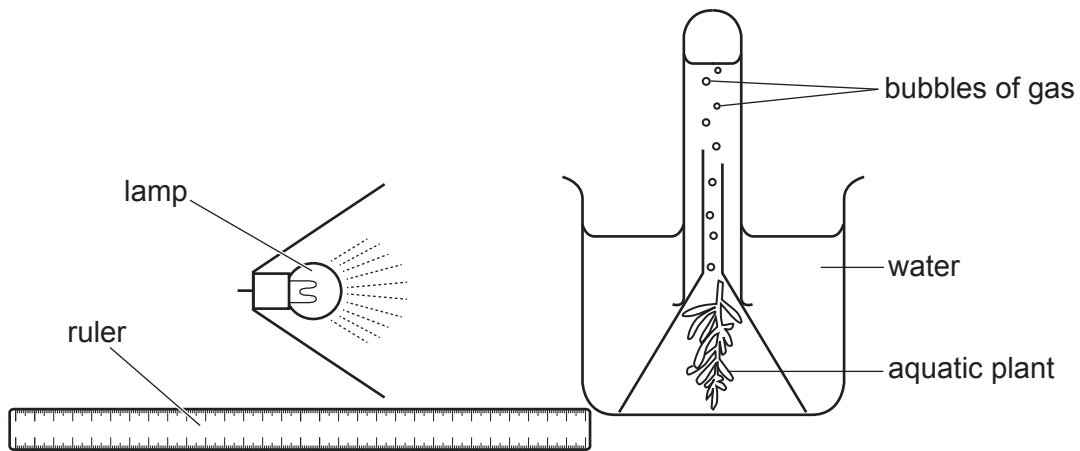

Fig. 1.3

The student:

- places the lamp 10 cm from the beaker
- counts the number of bubbles the aquatic plant produces in 3 minutes
- repeats the count two more times at this distance
- then repeats the experiment with the lamp at different distances from the beaker.

Table 1.1 shows the results.

Table 1.1

distance of lamp from beaker /cm	number of bubbles			average number of bubbles
	attempt 1	attempt 2	attempt 3	
10	120	118	123	120
20	118	120	119	119
30	80	78	75	78
40	48	45	42	45
50	15	12	14	

- (i) Calculate the average number of bubbles when the lamp is 50 cm from the beaker. Give your answer to the nearest whole number.

..... bubbles [2]

(ii) Describe the effect of light intensity on the rate of photosynthesis shown in Table 1.1.

.....
.....
.....
..... [2]

(d) Explain the role of chlorophyll in photosynthesis.

.....
.....
..... [2]

[Total: 11]

2 Oxygen and hydrogen are gases.

(a) The dot-and-cross diagrams in Fig. 2.1 show the outer shell electrons in a molecule of hydrogen and a molecule of oxygen.

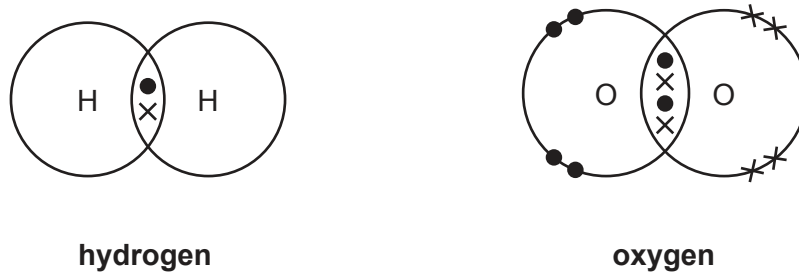

Fig. 2.1

(i) State how the dot-and-cross diagram for hydrogen shows that it contains a covalent bond.

.....
 [1]

(ii) The bonding in the hydrogen molecule is different from the bonding in the oxygen molecule shown in Fig. 2.1.

State **and** explain this difference.

difference

explanation

..... [2]

(b) Table 2.1 shows information about some gases in the air.

Table 2.1

gas	formula	percentage in air
oxygen	O ₂	21
nitrogen	N ₂	78
carbon dioxide	CO ₂	0.04
argon	Ar	0.93

(i) Identify the gas in Table 2.1 that is a compound.

Explain your answer.

gas

explanation

[2]

(ii) State **one** use for argon.

[1]

(iii) Argon is a noble gas.

Describe the reactivity of noble gases.

Use ideas about electronic structure in your answer.

[2]

(iv) Explain how the data show that air contains some gases which are **not** listed in Table 2.1.

[1]

[Total: 9]

- 3 Fig. 3.1 shows a motor boat moving forward across the sea.

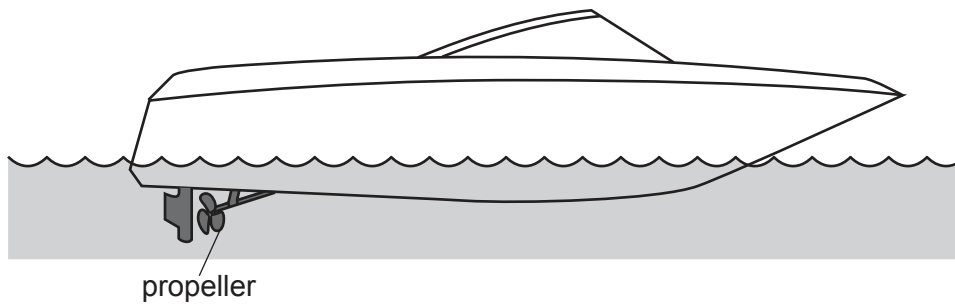

Fig. 3.1

- (a) The boat has a mass of 3100 kg and moves at a constant speed of 12 m/s.
- (i) Calculate the kinetic energy of the moving boat.

kinetic energy = J [2]

- (ii) The boat uses a gasoline (petrol) engine to turn the propeller.

Explain why even at constant speed the engine has to power the propeller to keep the boat moving forward.

Use ideas about forces and work done in your answer.

.....

.....

.....

.....

..... [3]

- (b) The boat enters a harbour. Waves from the boat hit the harbour wall. Fig. 3.2 shows water waves behind the boat hitting the harbour wall.

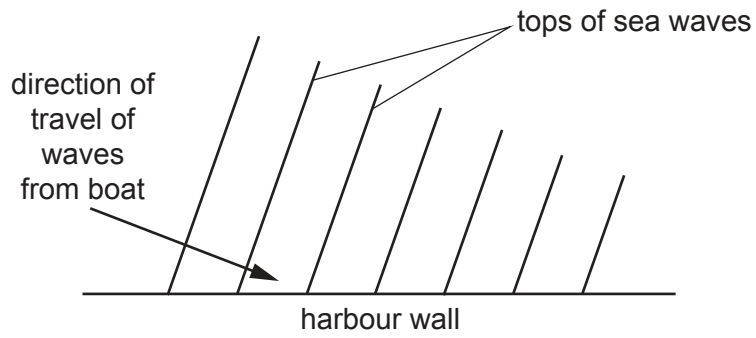

Fig. 3.2

- (i) State what happens to the waves when they hit the harbour wall.

..... [1]

- (ii) On Fig. 3.2 draw an arrow to show the direction of these waves after hitting the harbour wall. [2]

[Total: 8]

- 4 (a) Table 4.1 shows the mass of protein in some different food types.

Table 4.1

food type	mass of protein in 100 g of food /g
beans	6.9
cheese	25.4
eggs	12.5
fish	23.5
lentils	7.6
meat	32.0
nuts	21.1

- (i) Identify the food type that contains the most protein in 100 g of food.

..... [1]

- (ii) The recommended daily intake of protein for an adult male is 56g.
A man eats 25g of nuts.

Calculate the percentage of the recommended daily intake of protein he has eaten.
Give your answer to 2 significant figures.

.....% [3]

- (iii) Some people only eat vegetable proteins.

Suggest why eating nuts can be an important part of their diet.

Use the information in Table 4.1 to help you.

.....
..... [1]

(b) Proteins are digested in the stomach.

(i) Mechanical digestion and chemical digestion both take place in the stomach.

Compare mechanical digestion and chemical digestion.

.....
.....
.....
..... [2]

(ii) Hydrochloric acid is found in the stomach.

State why chemical digestion in the stomach requires the presence of hydrochloric acid.

.....
..... [1]

[Total: 8]

5 Some gas ovens use methane as a fuel, other gas ovens use propane.

(a) Complete and balance the equation for the **complete** combustion of propane.

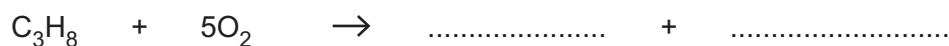

[2]

(b) Fig. 5.1 shows the energy level diagrams for the combustion of methane and the combustion of propane. The diagrams are drawn to the same scale.

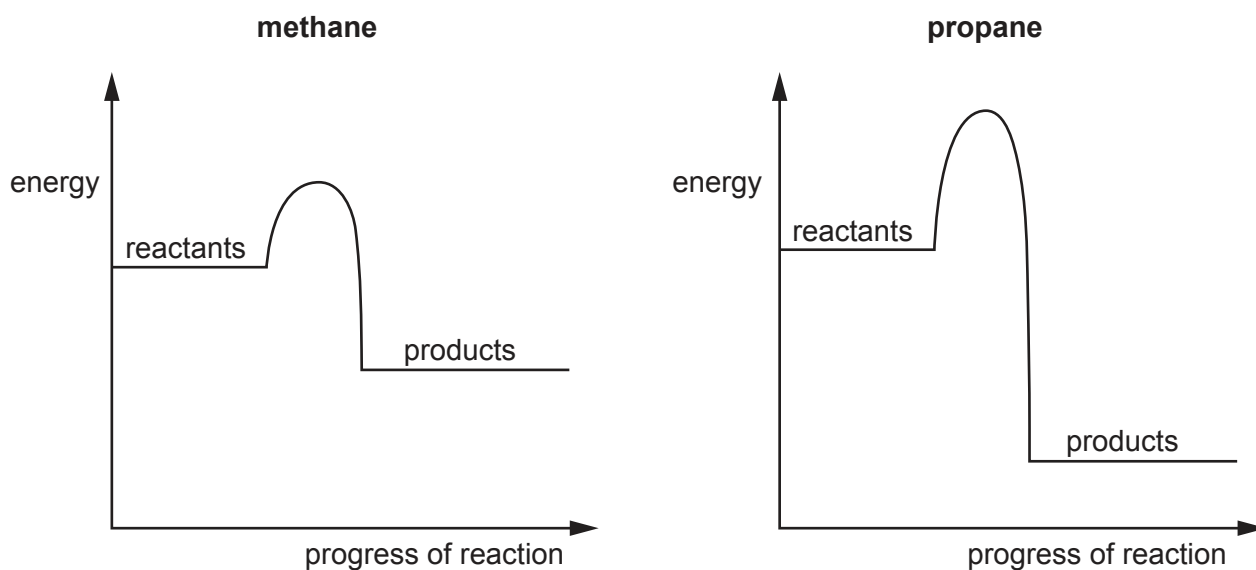

Fig. 5.1

(i) Explain how Fig. 5.1 shows that both reactions are exothermic.

.....

 [2]

(ii) Use Fig. 5.1 to state **two** differences between the energy changes that happen during the combustion of methane and the combustion of propane.

1

 2

[2]

(c) When the air supply to an oven is limited, carbon monoxide is formed.

State **one** adverse effect of carbon monoxide.

.....
..... [1]

[Total: 7]

- 6 (a) Fig. 6.1 shows a thermometer in a solution of salt in water. The salt solution is boiling.

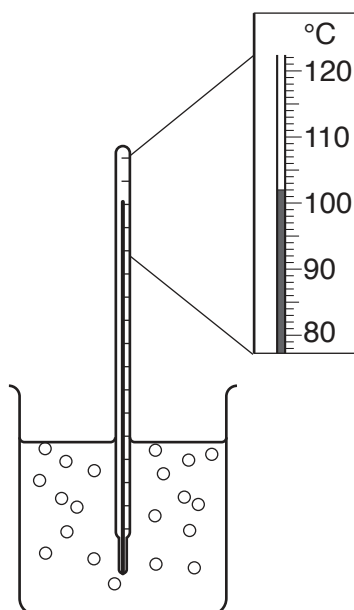

Fig. 6.1

- (i) Use the data in Fig. 6.1 to describe the effect on the boiling point of **pure water** of adding salt to water.

.....

.....

.....

..... [2]

- (ii) The addition of salt to water increases the forces between the particles.
Suggest why this causes the change in the boiling point of the liquid.

.....

..... [1]

- (b) Fig. 6.2 shows a tank full of water. The volume of water in the tank is 1500 dm^3 .

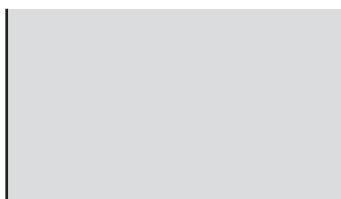

Fig. 6.2

Fig. 6.3 shows the same tank after a large rock fell into the tank. The water in the tank flowed over the top. When the rock was lifted out, only 1075 dm^3 of water was left in the tank.

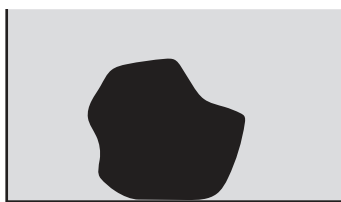

Fig. 6.3

The rock has a mass of 1150 kg.

- (i) Calculate the volume of the rock.

volume = dm^3 [1]

- (ii) Use your answer to **(b)(i)** to calculate the density of the rock.

density = kg/dm^3 [2]

- (iii) Calculate the weight of the rock.

The gravitational field strength, g , is $10 \text{ N}/\text{kg}$.

weight = N [1]

- (iv) The rock is lifted back into the tank. The water is emptied from the tank.

The area of the rock in contact with the base of the empty tank is 1.1 m^2 .

Use your answer to **(b)(iii)** to calculate the pressure of the rock on the bottom of the tank. Give the units of your answer.

pressure = units [3]

[Total: 10]

[Turn over

7 (a) Fig. 7.1 is a photomicrograph of a cross-section of an artery.

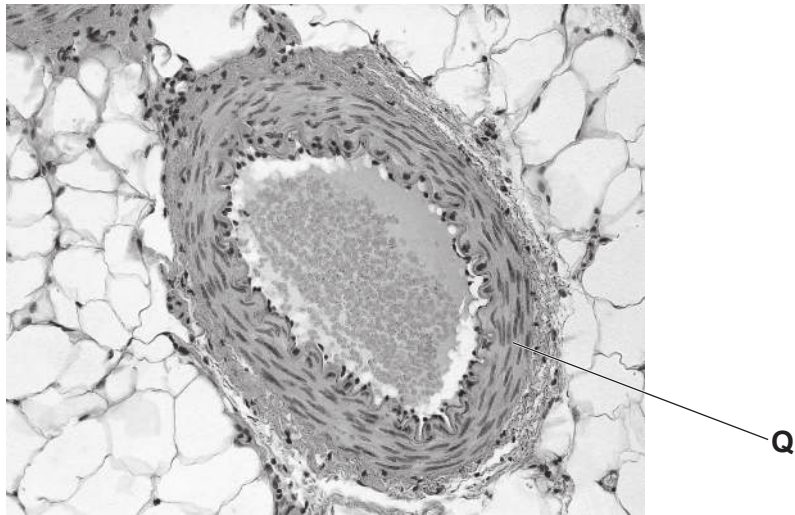

Fig. 7.1

(i) Identify the type of tissue labelled Q in Fig. 7.1.

..... [1]

(ii) Arteries form part of a double circulatory system in humans.

Explain the advantages of a double circulatory system.

.....
.....
.....
..... [2]

(iii) Blood flows through arteries due to the actions of the heart.
Describe how the heart pushes blood through the arteries.

.....
.....
.....
..... [2]

(b) Smoking tobacco is a risk factor for coronary heart disease.

Cigarettes contain tobacco.

Fig. 7.2 shows the correlation between number of cigarettes smoked and number of deaths from heart disease.

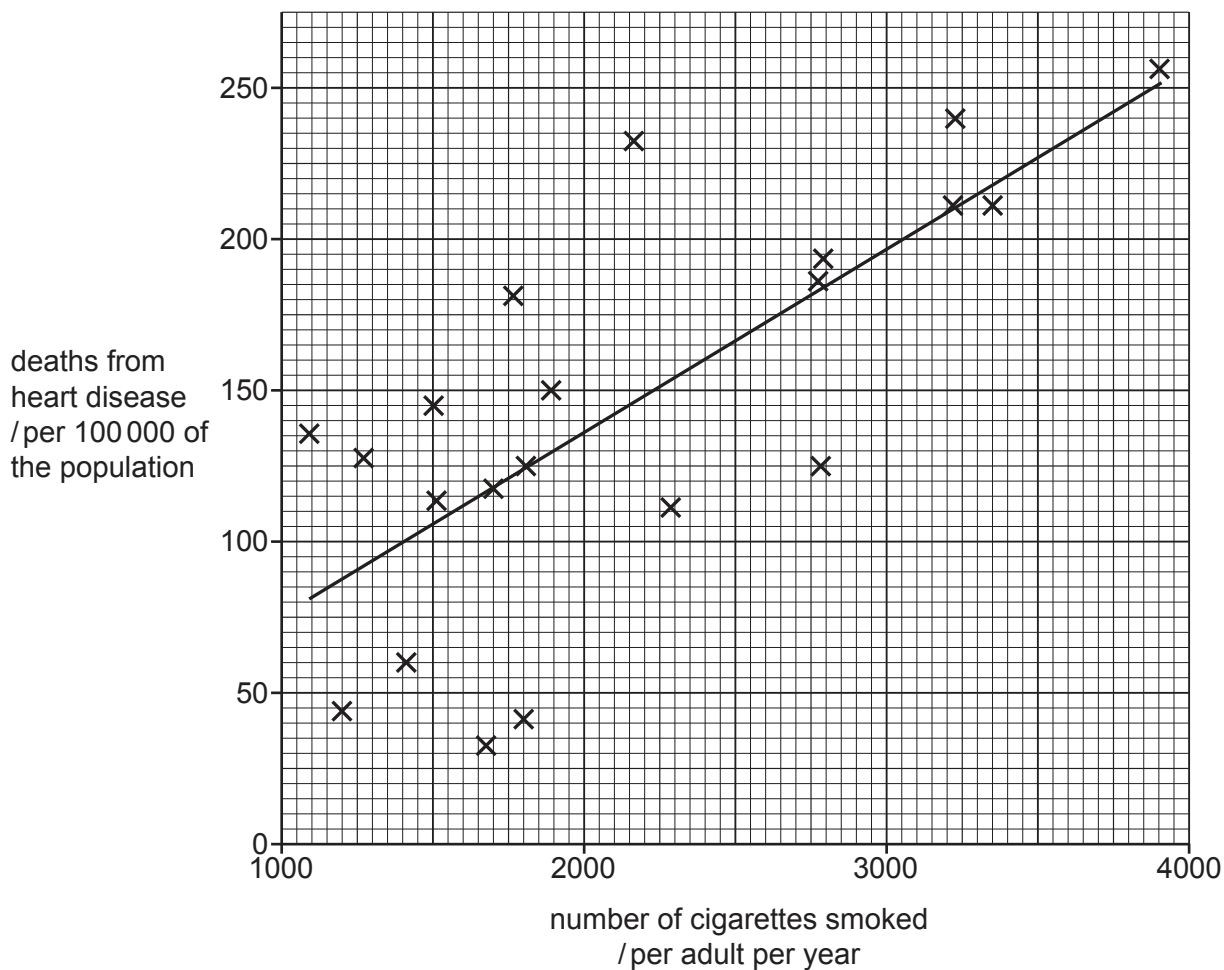

Fig. 7.2

(i) Describe the correlation in Fig. 7.2.

.....

..... [1]

(ii) Fig. 7.3 shows some cells which line a human airway.

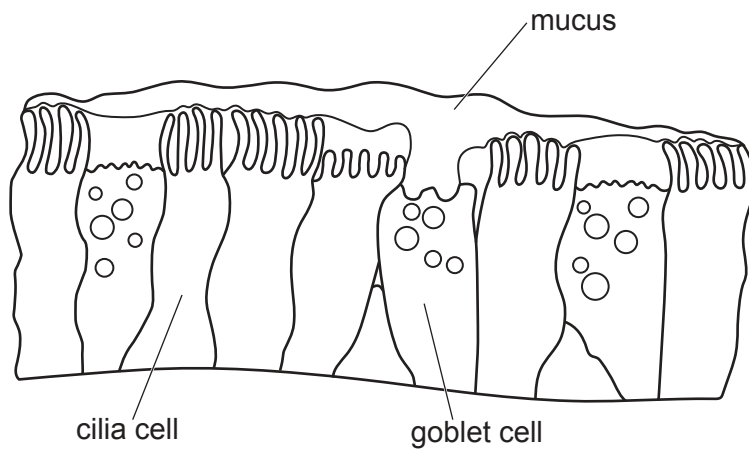

Fig. 7.3

Describe how the cells shown in Fig. 7.3 work to remove the particles inhaled in tobacco smoke.

.....

.....

.....

..... [2]

[Total: 8]

8 Bromine, chlorine and iodine are in Group VII of the Periodic Table.

Table 8.1 shows some information about these elements at room temperature and pressure.

Table 8.1

element	formula	state	colour
bromine	Br_2	liquid	red
chlorine	Cl_2		
iodine	I_2		grey

(a) (i) Complete Table 8.1. [3]

(ii) Molecules of bromine, chlorine and iodine are diatomic.

Explain the meaning of the term diatomic.

.....

.....

.....

..... [2]

(b) Explain why bromine, chlorine and iodine are in Group VII of the Periodic Table.

Use ideas about electrons in your answer.

.....

..... [1]

(c) Some Group VII elements are mixed with some aqueous potassium salts.

The word equations show what happens.

bromine + potassium chloride → no reaction

bromine + potassium iodide → iodine + potassium bromide

chlorine + potassium bromide → bromine + potassium chloride

iodine + potassium bromide → no reaction

Use this information to place bromine, chlorine and iodine in order of reactivity.

Explain your answer.

most reactive

↓

least reactive

explanation

..... [2]

(d) Potassium reacts with chlorine to form potassium chloride.

(i) State the type of bonding in potassium chloride.

..... [1]

(ii) Explain why potassium chloride has a high melting point.

.....

..... [1]

[Total: 10]

- 9 (a) Fig. 9.1 shows an incomplete circuit used to determine the resistance of a length of resistance wire.

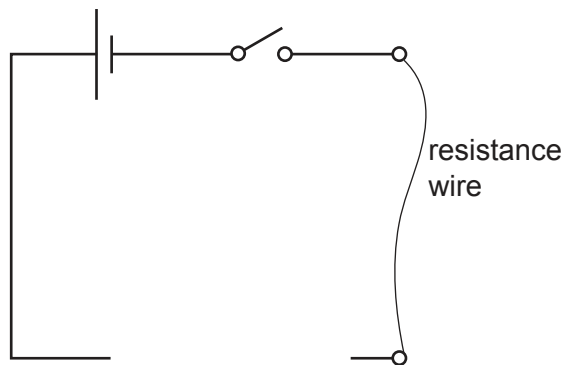

Fig. 9.1

- (i) Complete the circuit diagram by adding the symbols for the instruments used to measure the current and the potential difference across the resistance wire in the circuit. [2]
- (ii) The resistance wire is replaced by a new wire made of the same material, but three times the length and half the cross-sectional area.

The resistance of the first wire is $5.5\ \Omega$.

Calculate the resistance of the new wire.

resistance = Ω [3]

- (b) Fig. 9.2 shows a circuit with a piece of wire of resistance $5.0\ \Omega$ connected in parallel with another piece of wire of resistance $10.0\ \Omega$.

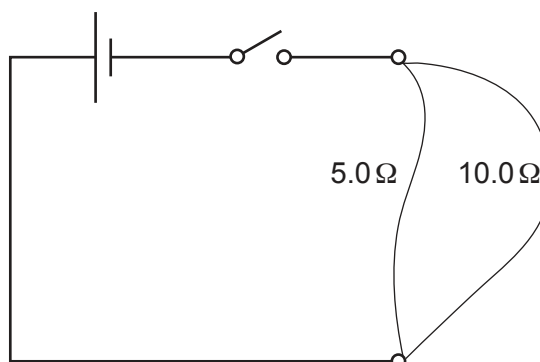

Fig. 9.2

(i) There is a current of 3.0 A from the source.

State the current in the 5.0 Ω resistance wire.

Explain your answer.

currentA

explanation

.....

[2]

(ii) Calculate the combined resistance of the two resistance wires in parallel.

resistance = Ω [2]

[Total: 9]

Permission to reproduce items where third-party owned material protected by copyright is included has been sought and cleared where possible. Every reasonable effort has been made by the publisher (UCLES) to trace copyright holders, but if any items requiring clearance have unwittingly been included, the publisher will be pleased to make amends at the earliest possible opportunity.

To avoid the issue of disclosure of answer-related information to candidates, all copyright acknowledgements are reproduced online in the Cambridge Assessment International Education Copyright Acknowledgements Booklet. This is produced for each series of examinations and is freely available to download at www.cambridgeinternational.org after the live examination series.

Cambridge Assessment International Education is part of the Cambridge Assessment Group. Cambridge Assessment is the brand name of the University of Cambridge Local Examinations Syndicate (UCLES), which itself is a department of the University of Cambridge.

The Periodic Table of Elements

		Group																			
I	II	III	IV	V	VI	VII	VIII														
3 Li lithium 7	4 Be beryllium 9	1 H hydrogen 1	5 B boron 11	6 C carbon 12	7 N nitrogen 14	8 O oxygen 16	9 F fluorine 19	10 Ne neon 20													
11 Na sodium 23	12 Mg magnesium 24	Key atomic number atomic symbol name relative atomic mass																			
19 K potassium 39	20 Ca calcium 40											13 Al aluminium 27	14 Si silicon 28	15 P phosphorus 31	16 S sulfur 32	17 Cl chlorine 35.5	18 Ar argon 40				
37 Rb rubidium 85	38 Sr strontium 88	21 Sc scandium 45	22 Ti titanium 48	23 V vanadium 51	24 Cr chromium 52	25 Mn manganese 55	26 Fe iron 56	27 Co cobalt 59	28 Ni nickel 59	29 Cu copper 64	30 Zn zinc 65	31 Ga gallium 70	32 Ge germanium 73	33 As arsenic 75	34 Se selenium 79	35 Br bromine 80	36 Kr krypton 84				
55 Cs caesium 133	56 Ba barium 137	39 Y yttrium 89	40 Zr zirconium 91	41 Nb niobium 93	42 Mo molybdenum 96	43 Tc technetium —	44 Ru ruthenium 101	45 Rh rhodium 103	46 Pd palladium 106	47 Ag silver 108	48 Cd cadmium 112	49 In indium 115	50 Sn tin 119	51 Sb antimony 122	52 Te tellurium 128	53 I iodine 127	54 Xe xenon 131				
87 Fr francium —	88 Ra radium —	57–71 lanthanoids	72 Hf hafnium 178	73 Ta tantalum 181	74 W tungsten 184	75 Re rhenium 186	76 Os osmium 190	77 Ir iridium 192	78 Pt platinum 195	79 Au gold 197	80 Hg mercury 201	81 Tl thallium 204	82 Pb lead 207	83 Bi bismuth 209	84 Po polonium —	85 At astatine —	86 Rn radon —				
		72 Hf hafnium 178	73 Ta tantalum 181	74 W tungsten 184	75 Re rhenium 186	76 Os osmium 190	77 Ir iridium 192	78 Pt platinum 195	79 Au gold 197	80 Hg mercury 201	81 Tl thallium 204	82 Pb lead 207	83 Bi bismuth 209	84 Po polonium —	85 At astatine —	86 Rn radon —					
		89–103 actinoids	104 Rf rutherfordium —	105 Db dubnium —	106 Sg seaborgium —	107 Bh bohrium —	108 Hs hassium —	109 Mt meitnerium —	110 Ds darmstadtium —	111 Rg roentgenium —	112 Cn copernicium —	114 Fl flerovium —	116 Lv livermorium —								

lanthanoids	57 La lanthanum 139	58 Ce cerium 140	59 Pr praseodymium 141	60 Nd neodymium 144	61 Pm promethium —	62 Sm samarium 150	63 Eu europium 152	64 Gd gadolinium 157	65 Tb terbium 159	66 Dy dysprosium 163	67 Ho holmium 165	68 Er erbium 167	69 Tm thulium 169	70 Yb ytterbium 173	71 Lu lutetium 175
actinoids	89 Ac actinium —	90 Th thorium 232	91 Pa protactinium 231	92 U uranium 238	93 Np neptunium —	94 Pu plutonium —	95 Am americium —	96 Cm curium —	97 Bk berkelium —	98 Cf californium —	99 Es einsteinium —	100 Fm fermium —	101 Md mendelevium —	102 No nobelium —	103 Lr lawrencium —

The volume of one mole of any gas is 24 dm³ at room temperature and pressure (r.t.p.).